

Drawing



Tools for Chefs

Hendi B.V.
Innovatielaan 6
6745XW De Klomp
The Netherlands

Batch #

V.02

Appliance part#

239698

Description

Induction cooker 3500W XL

Date 04-12-2025

Revision #

V.02

Revision Updated power control method (continuous heat)

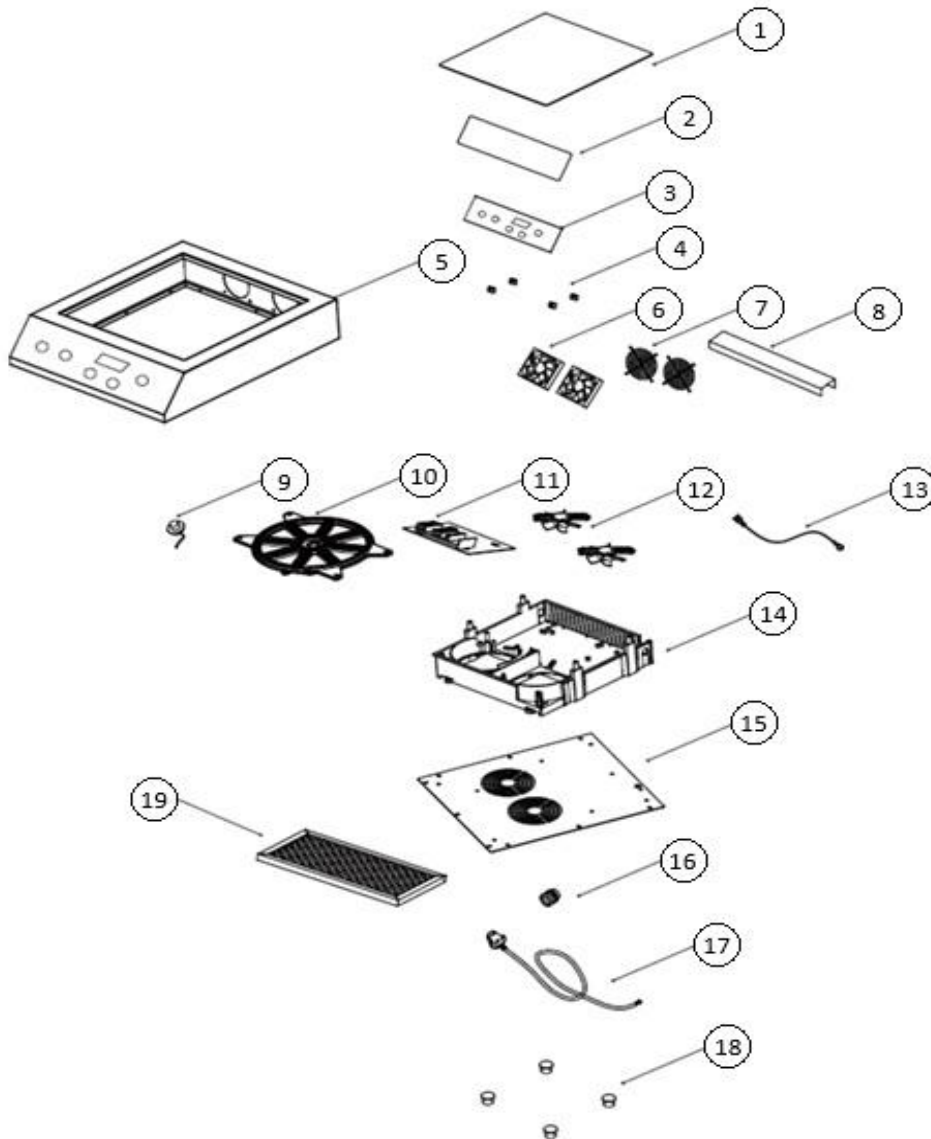

Bill of materials (BOM)

 <b style="font-size: 24px; margin-left: 10px;">HENDI <small style="color: green; margin-left: 10px;">Tools for Chefs</small> Hendi B.V. Steenoven 21 3911 TX Rhenen The Netherlands	Batch #	Appliance part#
	V.02	239698
	Description	
	Induction cooker 3500W XL	

Date	04-12-2025	Revision #	V.02
Revision	Updated power control method (continuous heat)		

Item	Description	Part#	Quantity	Remark	Picture
1	Ceramic glass	nss	1		
2	Control panel glass	nss	1		
3	Control PCB	971895	1		
4	Control PCB bracket	nss	4		
5	Upper housing	971901	1	Incl. item 1, 2, 5 and 8	
6	Fan (80*80mm)	901441	2		
7	Fan cover	n/a	2		
8	Bracket	n/a	1		
9	Sensor	932582	1		
10	Inducton coil	971918	1		
11	Main PCB	969830	1		
12	Fan (axial)	969847	1		
13	Wire	n/a	1		
14	Main PCB backet	n/a	1		
15	Housing panel (bottom)	n/a	1		
16	Pull relief	n/a	1		
17	Power cord	929353	1		
18	Feet	901373	4		
19	Filter	969854	1		

n/a -> not available

nss -> not sold separately

Wiring diagram

 <b style="font-size: 2em; margin-left: 10px;">HENDI Tools for Chefs Hendi B.V. Steenoven 21 3911 TX Rhenen The Netherlands	Batch #	Appliance part#
	V.02	239698
	Description	
	Induction cooker 3500W XL	

Date	04-12-2025	Revision #	V.02
Revision	Updated power control method (continuous heat)		

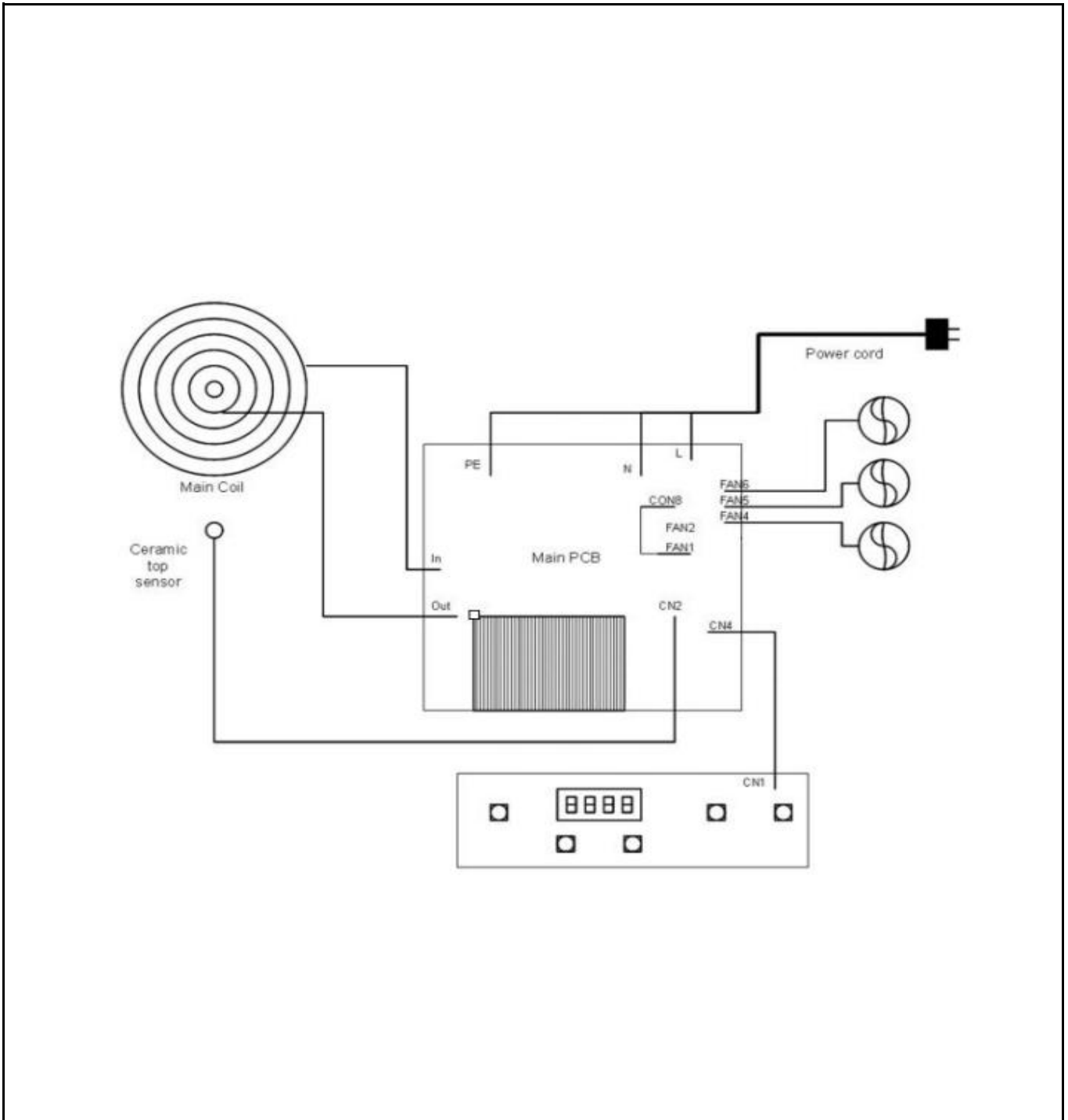

Dimentional drawing

 HENDI Tools for Chefs Hendi B.V. Steenoven 21 3911 TX Rhenen The Netherlands	Batch #	Appliance part#
	V.02	239698
	Description	
	Induction cooker 3500W XL	

Date	04-12-2025	Revision #	V.02
Revision	Updated power control method (continuous heat)		

